

1N5400~1N5408

HIGH CURRENT PLASTIC SILICON RECTIFIER

VOLTAGE 50 to 1000 Volts **CURRENT** 3.0 Ampere



DO-201AD

Unit: inch(mm)

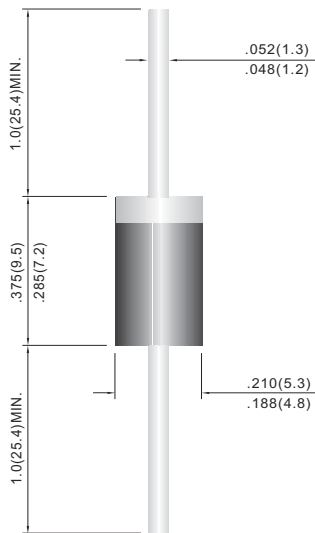

FEATURES

- Plastic package has Underwriters Laboratories Flammability Classification 94V-O utilizing Flame Retardant Epoxy Molding Compound.
- High current capability
- Low leakage
- Exceeds environmental standards of MIL-S-19500/228
- Pb free product are available : 99% Sn above can meet Rohs environment substance directive request

MECHANICAL DATA

Case: DO-201AD Molded plastic

Lead: Axial leads, solderable per MIL-STD-202G, Method 208 guaranteed

Polarity: Color band denotes cathode end

Mounting Position: Any

MAXIMUM RATINGS AND ELECTRICAL CHARACTERISTICS

Ratings at 25°C ambient temperature unless otherwise specified. Single phase, half wave, 60 Hz, resistive or inductive load. For capacitive load, derate current by 20%.

PARAMETER	SYMBOL	1N5400	1N5401	1N5402	1N5403	1N5404	1N5405	1N5406	1N5407	1N5408	UNITS
Maximum Recurrent Peak Reverse Voltage	V _{RRM}	50	100	200	300	400	500	600	800	1000	V
Maximum RMS Voltage	V _{RMS}	35	70	140	210	280	350	420	560	700	V
Maximum DC Blocking Voltage	V _{DC}	50	100	200	300	400	400	600	800	1000	V
Maximum Average Forward Current .375"(9.5mm) lead length at TA=55 °C	I _{AV}	3.0									A
Peak Forward Surge Current : 8.3ms single half sine-wave superimposed on rated load(JEDEC method)	I _{FSM}	200									A
Maximum Forward Voltage at 3.0A	V _F	1.2									V
Maximum DC Reverse Current at TA=25°C Rated DC Blocking Voltage TA=100°C	I _R	5.0 1000									uA
Typical Junction capacitance (Note 1)	C _J	30									pF
Typical Thermal Resistance(Note 2)	R _{θJA}	20									°C / W
Operating Junction and Storage Temperature Range	T _J , T _{STG}	-55 TO +125									°C

NOTES:

1. Measured at 1 MHz and applied reverse voltage of 4.0 VDC.
2. Thermal Resistance from Junction to Ambient and from junction to lead at 0.375"(9.5mm)lead length P.C.B.mounted.

1N5400~1N5408

RATING AND CHARACTERISTIC CURVES

